

## Heat Tracing Products

### Applications

#### *Electric Heat Tracing Products*

ProTherm heating cable line includes cables suitable for most process maintenance, pipe and vessel freeze protection and roof and gutter de-icing applications.

Industrial Heating Cables are ideal for process maintenance applications. Maintenance temperatures up to 1100°F can be achieved in a variety of hazardous and corrosive environments. Industrial Cables include:

**SRL** — Self-Regulating, Low Temperature

**SRP** — Self-Regulating Process Maintenance

**SRM/E** — Self-Regulating, Medium Temperature Enhanced

**SLL** — Constant Wattage, Medium Temperature

**CWM** — Constant Wattage, Medium Temperature

**MI** — Mineral Insulation, High Temperature

**Tube Bundles** — Pre-Installed/Traced Tube Bundles

Commercial Application Cables are designed to meet specific needs of winterizing applications such as water line freeze protection and preventing ice damage to building structures. Commercial Cables include:

**SRF** — Self-Regulating Freeze Protection

**SRF-RG** — Self-Regulating Roof and Gutter Freeze Protection

**HWM** — Hot Water Maintenance Applications

#### *Industrial Process Maintenance Applications*

When industrial process piping and vessels must be maintained above the ambient air temperature, ProTherm has the heating cable to fit the application. Cables range in the maximum maintenance temperature from 150°F for SRL to 1100°F for MI cables.

- Petroleum Refineries — Maintain petroleum and by-products at process temperature
- Waste Water Treatment Facilities — Prevent the precipitation of NaOH from solutions
- Food Processing Plants — Maintain viscosity of products in processes such as chocolate, oils and tallow
- Instrument Lines
- Storage Tanks
- Div. 1 and Div. 2 Hazardous Location Applications (Contact your Local Chromalox Sales office for Div. 1 applications)
- Freeze Protection of Steam Cleaned Lines
- Power Generating Plants — Trace steam condensate lines and other chemical additive lines
- Asphalt Lines

#### *Commercial Applications*

In a large number of regions in the world, buildings are susceptible to damage caused by water freezing. Primarily, this damage involves either the bursting of pipes or structural damage due to the weight of ice and snow building up on the roof. ProTherm Commercial Application Cables are intended to prevent this damage.

- Cooling Tower Pipes
- Parking Garage Drain Lines
- Chiller Water Lines
- Exposed Pipe Traps
- Exposed Storm Water Pipes
- Sump Discharge Pipes and Equipment
- Wet Sprinkler Fire Systems, where approved by Local Codes
- Outdoor Sports Facilities and Stadiums
- Roof and Gutter De-icing
- Hot Water Maintenance

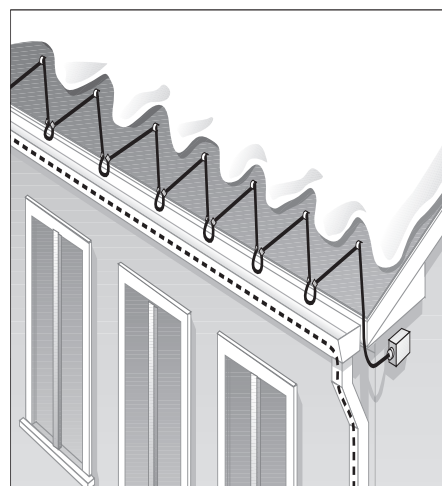
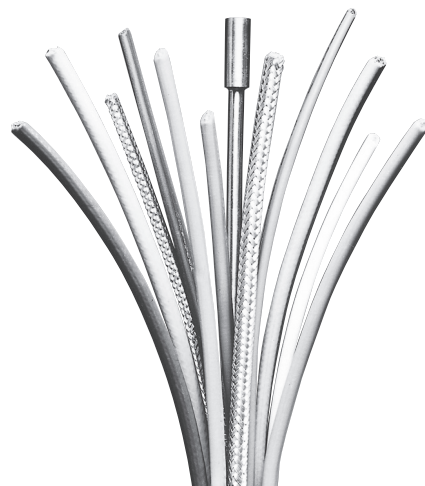

## Heat Tracing Products

### Industrial & Commercial Grade Cables & Control Systems

#### Heat Tracing Products — Section Outline

Type	Model	Page
Industrial - Application Guidelines		G-5
Self-Regulating		
Low Temperature	SRL	G-10
Process Temperature	SRP	G-13
Medium Temperature	SRM/E	G-16
Long Line Cable	SLL	G-19
Constant Wattage	CWM, SLL	G-22
Mineral Insulated	MI	G-25
Hazardous Location		
Low Temperature	HSRL	G-31
Medium Temperature	HSRM	G-34
Commercial - Application Guidelines		G-38
Self-Regulating Freeze Protection	SRF	G-37
Hot Water Maintenance	HWM	G-45
Roof & Gutter	SRF-RG	G-45
Edge Cutter System	PLD-EC	G-47
Snow Melt Mats	WSMM	G-49
Snow Melting Controls	APS-4C, APS-3C, SC-40C, PD Pro, GF Pro, LCD-1, CIT-1, GIT-1, SIT6-E, RCU	G-51 to G-64
U Series	UPC, UMC, UES, UESL, UBC, UAS, CCH-2, RTES, SSK, SPA, AT-1, FT-3, PS-1, PS-3, PS-10	G-65 to G-70
DL Series Integrated Connection Accessories	RTPC, RTST, RTES RTPC-SL, RTST-SL	G-71 to G-75
EL Series Standard Connection Accessories	SSK, PJB, RT-RST, RT-TST, RT-RES, RT-TES	G-76 to G-77
General Application Accessories	AT-1, FT-3, PS-1, PS-3 PS-10, BL-1, BL-2, BL-3, ST-1, CL-1, CCH-2	G-78

Type	Model	Page
HL Series (Div. 1 Connection Kits)	HL-PC, HL-S, HL-T HL-ES, D1SL1, DLSSL2	G-79
Freeze Protection Thermostats	THR, THL, TXR, TXL	G-83
B100/E100 Thermostats		G-85
RBF Heat Trace Sensor (RTD Kit)	RBF	G-87
Tubing Bundle		
Pre-Insulated Tubing	2200 Series 2210 Series	G-88 G-90
Low Temperature Maintenance Self-Regulating Electric Traced Tubing	2256 LTM, 2266 LTM	G-92
High Temperature Maintenance Self-Regulating Electric Traced Tubing	2256 HTM, 2262 HTM	G-94
Constant Wattage Electric Traced Tubing	2252 CPD, 2262 CPD	G-96
Single & Multiple Process Tube Heavy Steam Traced Bundles for High Temperature Applications	2211-2213	G-98
Tubing Bundle Accessories		G-101
DL Series Integrated Temperature Controls	RTAS, RTBC, RTAS-EP, RTBC-EP	G-105
Heat Trace Control & Panel Selection Guide		G-108
Electronic Controls & Control Panels	DTS, ITC, ITAS, ITLS, ITASC1D2, ITLSC1D2 FPAS, FPLS, FPASM, FPLSM	G-110 to G-142
Skin Effect	TTEP	G-143
Impedance Heating System		G-144

#### Industrial Cable Applications

##### Self-Regulating

ProTherm SRL, SRP and SRM/E Self Regulating Heating Cables provide the most versatility in heat trace designs and applications. Constructed of a semiconductive heater matrix extruded between parallel buss wires, a self-regulating cable adjusts its output to independently respond to temperatures all along its length. As temperatures increase, the heater's resistance increases which lowers the output wattage. Conversely, as the temperature decreases, the resistance decreases and the cable produces more heat. The result — an energy efficient heating cable.

Self-regulating cables are flexible, can be cut-to-length in the field and can be overlapped without fear of burnout in areas where complex piping and equipment require additional heat trace cable.

ProTherm manufactures low (SRL) Process (SRP) and medium (SRM/E) temperature self-regulating heating cable for use on 120 and 208 to 277V. Equipped with a ground braid and optional TPR or FEP jacket, ProTherm self-regulating cables are third party tested and approved for use in harsh corrosive and hazardous applications.

##### Constant Wattage

ProTherm CWM Constant Wattage Heating Cables are ideally suited for applications where a particular watt density is required at all times. The heater element consists of a nichrome wire wrapped around parallel, insulated buss wires. At specific intervals, a short section of insulation is removed from alternating buss wires to create connection nodes for the nichrome wire. The result is a network of parallel resistors along the entire length of constant wattage cable.

Constant wattage cables are flexible, can be cut-to-length in the field, and are manufactured for use on voltages from 120 to 480V. Although not suited for overlapping, its constant output makes it an ideal choice for higher temperature applications where higher watt densities are required. Equipped with a ground braid and optional FEP jacket, ProTherm constant wattage cables are third party tested and approved for use in harsh, corrosive and hazardous areas. Contact your local ProTherm Sales office for hazardous area designs.

## Heat Tracing Products

### Industrial & Commercial Grade Cables (*cont'd.*)

#### ***SLL Series Long Line Cables***

ProTherm SLL Series Long Line cable provides safe, reliable heat tracing for process temperature maintenance and freeze protection of pipes, valves, tanks and similar applications. Constructed of industrial grade 16, 14, 12 or 10 AWG buss wire with metal braid and fluoropolymer overjacketing, SLL ensures operating integrity in most hostile industrial environments. The 450°F (232°C) maximum exposure temperature rating allows steam cleaning of process equipment with up to 300 psig steam.

#### ***Mineral Insulated***

ProTherm MI Mineral Insulated Heating Cables are the most rugged heating cable in ProTherm's product line. Constructed of a solid series resistor element embedded in highly compacted mineral insulation, MI cables are built to handle high temperature, high wattage applications. The series resistor and mineral insulation are encased in a metallic jacket of Alloy 825 for high temperature or corrosive applications.

Mineral insulated cables are factory assembled and tested, ensuring the highest quality product. Since the units consist of a series resistor, virtually any wattage/voltage/length cable configuration can be produced within the cable's physical operating limits. ProTherm mineral insulated cables are available for use up to 600V and are tested and approved for use in corrosive and hazardous areas. Optional accessories include pulling eyes and reverse glands. Other special features are also available.

#### ***Commercial Cable Applications Self-Regulating Freeze Protection***

ProTherm SRF Self Regulating Freeze Protection Heating Cable is a self-regulating cable designed for the freeze protection of water lines. The self-regulating matrix allows for overlapping and easy field installation. SRF also lowers its output and energy consumption as the temperature increases thus lowering energy costs. The 16 AWG buss wires provide for long circuits which reduce the number of accessories required.

A braided and braided with overjacket construction is available. Braided cable should be used on dry pipes and dry locations. The overjacket construction is suitable for wet locations where occasional exposure to moisture is expected.

SRF heating cable is not for use in hazardous locations. Consult the Industrial Cable Products in this section for cables suitable for hazardous locations.

#### ***Self-Regulating Hot Water Maintenance***

HWM Cable is specifically designed for hot water temperature maintenance applications. HWM features a self regulating matrix that varies its output to accommodate changes in ambient or pipe temperature. This cable is designed to make up heat losses through the piping insulation and maintain consistent pipe temperatures for sink, shower, dishwashing, laundry, and kitchen service applications. HWM will maintain temperatures between 90°F and 140°F for these applications with service voltages between 120 and 277 volts. Circuit lengths up to 500 feet are available. HWM cable and accessories provide a low cost alternative to expensive recirculation systems for domestic hot water temperature maintenance applications.

#### ***Self-Regulating Roof & Gutter De-Icing***

SRF-RG Heating Cable is specifically designed for roof and gutter de-icing applications. SRF-RG features a self-regulating matrix that reduces output as snow melt requirements decrease or when warm weather is present.

The braided and overjacketed construction provides reliable moisture protection. The 16 AWG buss wires allow ample circuit lengths and rugged design. Accessories are available for mounting to roofs and gutters.

## Heat Tracing Products

### Application & Selection Guidelines

#### General Product Summary

This section is designed to assist you in determining the appropriate cable for use in your application.

**Step 1** — Collect Required Application Data and Determine Heat Loss

**Step 2** — Choose the cable that best meets your specific application parameters based on the summary. Consideration of application temperature, exposure temperature, application requirements and environmental ratings should be made.

**Step 3** — Select Heating Cable Wattage Rating

**Step 4** — Determine Total Cable Required

**Step 5** — Determine Circuits and Circuit Protection

**Step 6** — Select Appropriate Accessories

#### Step 1 — Collect Required Application Data & Determine Heat Loss

Application data required can be split into two categories. The first is the heat loss data. This includes:

- Maintenance Temperature
- Minimum Ambient Temperature
- Pipe Size
- Insulation Type (or K factor)
- Insulation Thickness
- Indoor/Outdoor Installation
- Maximum Expected Wind Speed
- Required Safety Factor.

Refer to the Technical section of this catalog, “Determining Heat Energy Requirements — Pipe & Tank Tracing” for details on

performing heat loss calculations. For Commercial Freeze Protection, please see Cable Selection Tables in this section.

The second category of data required is the application and environmental conditions. This includes:

- Maximum Exposure Temperature (Power Off Condition)
- Circuit Length Considerations
- Available Voltage
- Hazardous Area Requirements
- Type of Pipe (Plastic or Metal)
- Chemical Exposure
- Fire Resistance.

#### Step 2 — Select the Cable

Choose the cable that best fits your specific application parameters and wattage requirements.

#### Heat Tracing Product Features

Features	Industrial						Commercial		
	SRL	SRP	SRM/E	CWM	SLL	Alloy 825 MI	SRF	SRF-RG	HWM
Max. Maintenance Temp. (°F)	150	225	302	320	302	900	100	50	225
Max. Exposure Temp. (°F) Power Off	185	275	420	400	450	1,100	185	185	275
Max. W/Ft.	10	15	20	12	12	50	8	12	15
Max. Circuit Length (Ft.)	95-660	55-750	150-750	225-900	7,500	330-1,000	180-660	135-540	500-800
Buss Wire Size	16	16	16	12	16,14,12,10	N/A	16	16	16
Voltages	120, 208-277	120, 208-270	120, 208-277	120, 208-277, 480	120-600	Up to 600	120, 208-277	120, 208-277	120, 208-270
Hazardous Ratings	Yes	Yes	Yes	Yes	Yes	Yes	No	No	No
Usable on Plastic Pipe	Yes	No	No	No	No	No	Yes	Yes	Yes
Cut-to-Length in Field	Yes	Yes	Yes	Yes	Yes	No	Yes	Yes	Yes
Field Splicable	Yes	Yes	Yes	Yes	Yes	No	Yes	Yes	Yes
Can be Overlapped	Yes	Yes	Yes	No	No	No	Yes	Yes	Yes
Output Varies with Temp.	Yes	Yes	Yes	No	No	No	Yes	Yes	Yes
Varies Output Along Length	Yes	Yes	Yes	No	No	No	Yes	Yes	Yes
Design of System	Simple	Simple	Simple	Simple	Involved	Involved	Simple	Simple	Simple
Installation of System	Easiest	Easiest	Easiest	Simple	Simple	Involved	Easiest	Easiest	Easiest
Fire Resistance	Fair	Fair	Fair	Fair	Fair	Excellent	Fair	Fair	Fair
Chemical Resistance	See Corrosion Guide, next page								
Size (Max. In.)	.435x.185	.435x.185	.435x.185	.435x.235	.435x.185	0.4	.435x.185	.435x.185	.435x.185
Accessories	DL/EL/U	D/UL	DL/U	DL/EL/U	U		DL/EL/U	RG Access.	DL/U
Monitor Wire Available	Yes	Yes	Contact Factory	Contact Factory	No	No	No	No	Yes
Applications	FL,PL	FL,FH, PL,PH	FL,FH, PL,PH	FL,FH, PL,PH	FL,FH, PL,PH	FL,FH, PL,PH	FL	RG	HWM
	FL = Freeze Protection FH = Freeze Protection, High Exposure Temp. PL = Process Maintenance, Low Temperature					PH = Process Maintenance, High Temperature RG = Roof and Gutter De-icing HWM = Hot Water Maintenance			

# Heating Cable

## Heat Tracing Products

### Application & Selection Guidelines (cont'd.)

#### Agency Approvals

Area	SRL-C	SRL-CR	SRL-CT	HSRL	SRM/E-C	SRM/E-CT	SRP	HSRM	CWM-C	CWM-CT	MI	SRF-C	SRF-CR	SRF-RG	HWM
<b>Ordinary Area</b>															
UL	✓	✓	✓	✓	✓	✓	✓	✓	✓	✓	*	✓	✓	✓	✓
Factory Mutual	✓	✓	✓	✓	✓	✓	✓	✓	✓	✓	✓	✓	✓	✓	✓
CSA	✓	✓	✓	✓	✓	✓	✓	✓	✓	✓	✓	✓	✓	✓	✓
ATEX	✓	✓	✓	✓	✓	✓	✓	✓	✓	✓	*	✓	✓	✓	✓
<b>Class 1 Div 2, Groups B,C,D</b>															
UL											*				
Factory Mutual	✓	✓	✓	✓	✓	✓	✓	✓	✓	✓	✓				
CSA	✓	✓	✓	✓	✓	✓	✓	✓	✓	✓	✓				
ATEX							✓	✓	✓	✓	*				
<b>Class II Div 2, Groups FG</b>															
UL											*				
Factory Mutual	✓	✓	✓	✓	✓	✓	✓	✓	✓	✓	✓				
CSA	✓	✓	✓	✓	✓	✓	✓	✓	✓	✓	✓				
ATEX											*				
<b>Class III Div 2</b>															
UL											*				
Factory Mutual	✓	✓	✓	✓	✓	✓	✓	✓	✓	✓	✓				
CSA	✓	✓	✓	✓	✓	✓	✓	✓	✓	✓	✓				
ATEX											*				
<b>Class 1 Div 1, Groups B,C,D</b>															
UL											*				
Factory Mutual				✓				✓			*				
CSA				✓				✓			*				
ATEX											*				
<b>Class II Div 1, Groups FG</b>															
UL											*				
Factory Mutual				✓				✓			*				
CSA				✓				✓			*				
ATEX											*				
<b>Class III Div 1</b>															
UL											*				
Factory Mutual				✓				✓			*				
CSA				✓				✓			*				
ATEX											*				
<b>Zone 2 and Zone 22</b>															
Factory Mutual			✓			✓	✓				*				
CSA			✓			✓	✓				*				
ATEX			✓			✓	✓				*				
<b>Zone 1 and Zone 21</b>															
Factory Mutual											*				
CSA											*				
ATEX											*				

\*Class I, Division I, Groups B,C & D - UL, CSA, FM - Contact your Local ProTherm Sales office for design assistance.

#### Corrosion Guide to Select Proper Cable Construction

Exposure To	Industrial									Commercial		
	SRL	SRM/E	SRP	HSRL	HSRM	CWM	SLL	Alloy 825 MI	SRF	SRF-RG	HWM	
Moisture	C, CR, CT	C, CT	C, CT	CT	CT	C, CT	CT	Yes	C, CR	Yes	C, CT	
Aqueous Solutions of Inorganic Compounds	CR, CT	CT	CT	CT	CT	CT	CT	No	No	No	CT	
Liquids Organic Chemicals	CT	CT	CT	CT	CT	CT	CT	Yes	No	No	CT	
Acids or Bases	CT	CT	CT	CT	CT	CT	CT	No	No	No	CT	

**Note** — This is a recommendation guide. ProTherm cannot warrant any Electric Heat Trace against failure by sheath degradation if such failure is the result of operating conditions beyond the control of the heater manufacturer. It is the responsibility of the purchaser to make the ultimate choice of sheath material based on knowledge of the chemical composition of the corrosive solution, character of materials entering the solution, and controls which maintains the process.



## Heat Tracing Products

### Application & Selection Guidelines (cont'd.)

#### Required Jacket Material

Select the appropriate jacket configuration for the desired level of mechanical and corrosive chemical protection. The CR over-jacket option can be used when additional mechanical protection is desired. The CR over-jacket option is required when the cable can be exposed to aqueous inorganic chemicals. The CT over-jacket option is required when the cable can be exposed to organic chemicals or strong corrosives. Use Corrosion Guide above to determine the correct jacket material option for the cable type selected.

#### Step 3 — Select Heating Cable Wattage Rating

After calculating the heat loss in the pipe and adjusting for any application deviations, you may determine which cable rating to use. If you have selected a self-regulating cable you must adjust the output based on maintenance temperatures, using the Thermal Output Rating Graphs shown on the individual product pages, select the lowest cable rating that will provide the pipe maintenance temperature. **For Example:** A 15 W/Ft. SRM/E cable @ 150°F will output approximately 10 W/Ft. Multiple passes or runs of cable may be required to provide sufficient output per foot calculated in Step 1. This is accomplished with parallel runs of cable or spiraling. Contact your Local Chromalox Sales office.

#### Cable Output vs. Temperature

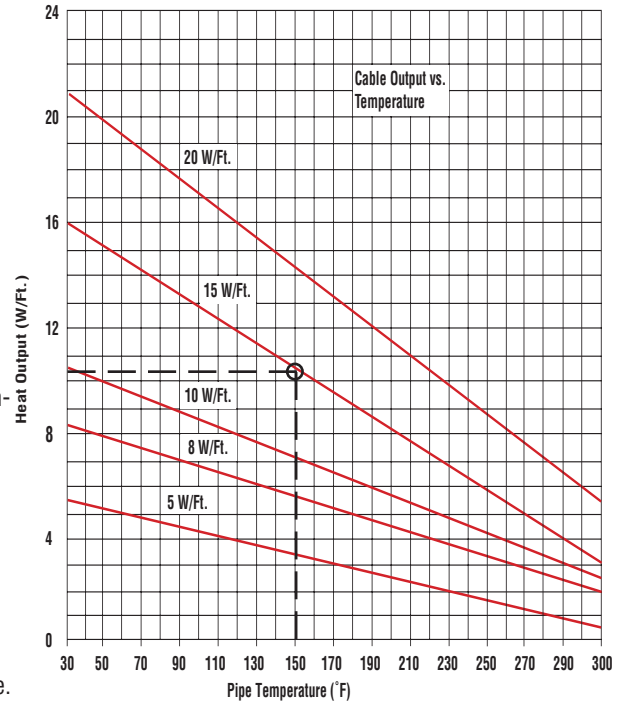

#### Step 4 — Determine Total Length of Cable Required

The total amount of heating cable is determined by adding the total footage of pipe to be traced and adding for allowances for the components such as flanges, valves, pipe supports; then, multiply by the total number of runs or Wrap Factor determined in Step 3.

(Total Feet of Traced Pipe + Cable Allowance for Components) x # of Runs = Total Cable Length

#### Step 5 — Determine Circuits & Circuit Protection

Circuit protection depends on the breaker size being used and the start-up temperature. The National Electric Code (NEC 1996) requires the use of ground fault protection breakers for heating cable. Refer to the specific data of the individual heat trace cable to determine maximum circuit lengths. To determine the number of circuits required for each pipe, divide the total cable length found in Step 4 by the maximum circuit length found in the individual cable data charts. Round up to the next higher number.

$$\text{Number of Circuits} = \frac{\text{Cable Length}}{\text{Maximum Circuit Length}}$$

#### Pipe Component Cable Allowance Estimation

Component	Cable Allowance Factor (Ft.)	x	# Components	Total Additional Cable
Flange Pair	1.5	x		
Pipe Support	2.0	x		
Butterfly Valve	2.5	x		
Ball Valve	2.7	x		
Globe Valve	4.0	x		
Gate Valve	5.0	x		

**Example:** Pipe: 150 feet  
 Valves: 1 globe valve  
 Pipe Supports: 2  
 Flanges: 2  
 Total Cable Length = [150 + (1 x 4) + (2 x 2) + (2 x 1.5)] x 2 runs  
 = 161 feet x 2 runs  
 = 322 feet

## Heat Tracing Products

### Application & Selection Guidelines (*cont'd.*)

#### *Design of Multiple Runs when Heat Requirements Exceed Cable Output Ratings*

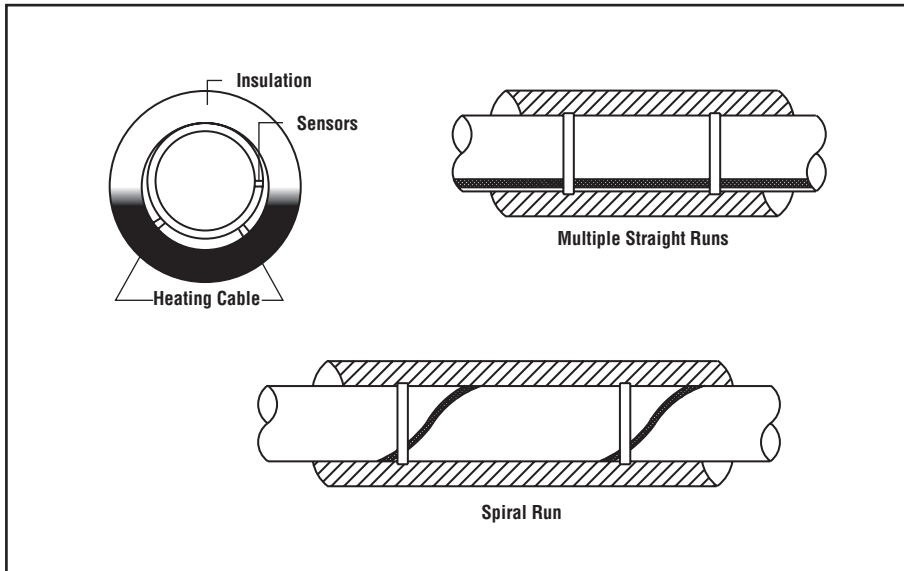

#### *Step 6 — Select Controls & General Application Accessories*

ProTherm provides a wide range of termination accessory and control options for your heat tracing systems needs.

Accessory options range from ordinary area under the insulation kits in our EL series all the way through connections and terminations for Division 1 hazardous areas in our HL series. The accessories carry a full complement of third party approvals from UL, Factory Mutual, Canadian Standards, ATEX and IECex.

Controls range from Thermostats for both ambient air and pipe/tank sensing applications to WeatherTrace power distribution and controls panels through our IntelliTrace line of distribution, monitoring and control panels. Whether your project is a few lines of freeze protection or a few hundred lines of process piping we have the right control option for your needs.



*More Information is Available Online on Heat Trace.*

#### *Accessory Descriptions*

##### **U Series**

- Designed for Ordinary and Hazardous Area use in Industrial applications
- Integrated design allows for quick cable termination
- Line carries worldwide approvals including ATEX and IECex
- Reduced parts count results in fast installation times
- Line includes:
  - Power Connection
  - Multi Entry Connection (for splice, tee or multiple power to 3 cables)
  - Above Insulation End Seal
  - Below Insulation End Seal
  - Lighted End Seal
  - Ambient Thermostat
  - Line Sensing Thermostat
  - Lighted End Seal
- Thermostats also serve as power connection for cable - eliminating need for extra power connection box.

##### **DL Series**

- Designed for Ordinary and Hazardous Area use in Industrial Applications
- Integrated design allows for fast installation
- Box design allows easy access for field wiring, maintenance and trouble shooting
- CSA, Factory Mutual and UL approved for ordinary and Hazardous area use (Div. 2)
- Line Includes
  - Power Connection
  - Splice and Tee (connect up to 3 cables)
  - Below Insulation End Seal
  - Lighted End Seal (ordinary area use only)
  - Ambient Thermostat
  - Line Sensing Thermostat
- Thermostats also serve as power connection for cable - eliminating need for extra power connection box.

## Heat Tracing Products Application & Selection Guidelines *(cont'd.)*

### EL Series

- Designed for use in ordinary areas for both commercial and industrial applications
- Low profile designs allow for ease of insulation around connections
- Kits include standard electrical terminations and heat shrink products familiar to most installers
- Low parts count allows fast termination of cables
- Third Party Approvals through UL, Factory Mutual and CSA.
- Line Includes
  - Junction Box
  - Pipe Stand off with sealing grommets and cable boots
  - Heat shrink splice and tee kits
  - Heat Shrink end caps

### HL Series

- Specifically designed for use in Division 1 hazardous areas
- Corrosion Resistant housing made of high strength cast aluminum
- Reduced parts count for fast installation
- Small profiles for ease of insulation
- Line Includes
  - Power Connection
  - Splice Kit
  - Tee Kit
  - End Seal Kit
  - Add on Signal lights for End Seal and Power Connection

### Controls Descriptions

#### DL Controls

The DL Series temperature controls are available in four models to handle a broad range of applications. Models include two ambient sensing and two line sensing thermostats. These high quality models combine On/Off temperature control and cable power connection in one affordable, convenient easy to install package. The line includes two 22 amp capable models for Ordinary Area installations and two 11 amp capable hermetically sealed models for Division 2 hazardous area applications. Products carry UL, Factory Mutual and CSA approvals.

#### EL Controls

The EL controls line contains ambient and line sensing controllers for use in Division 1 and Division 2 areas. All products switch 22 amps and come in NEMA 4x and NEMA 7 rated enclosures. Two models are available in dual output form. All capillaries are nontoxic oil filled available in 8 and 10 foot lengths. Products carry UL, Factory Mutual and CSA approvals.

#### WeatherTrace Control and Distribution Panels

The ProTherm FPAS, FPASM, FPLS, and FPLSM series panels offer power distribution, ground fault protection, individual circuit alarming, with options for both line sensing and ambient sensing control. Line sensing is accomplished in conjunction with U SERIES, DL SERIES or EL SERIES thermostats. Ambient sensing can be accomplished with thermostats or optional Chromalox solid state 1604 series temperature controllers. The panels are housed in NEMA 4 enclosures for indoor/outdoor applications. NEMA 4X 304 stainless steel enclosures may be selected as an option for more harsh environments. The standard models are available in 12,18,20,30 and 42 position panel boards with 100 and 225 amp bus ratings in single and three phase configurations. Branch circuit breakers are available in 20, 25, 30 and 40 amp single pole and two pole configurations with 30mA ground-fault equipment protection. Options for Z-purge systems for hazardous area installation are available. Sentinel monitoring system is available for alarm indication when a circuit loses power. Common alarm available for interface to building management systems. Panels are built in a UL 508 certified manufacturing plant and carry UL and cUL approvals.

#### DTS Digital Thermostat

The DTS-HAZ is a single circuit controller which switches 30 Amps at 100-277 Vac in Class I, Division 2 areas. It employs SSR on/off control, soft start feature, programmable paramater values, AC or DC alarm and large LED display. It comes complete with a standard pipe stand or optional wall mount as well as an RTD sensor. All of this is housed in a 6" x 6" enclosure, wich facilitates all wiring needs.

#### IntelliTRACE® ITC Series

The ITC is a 1 or 2 circuit microprocessor-based temperature controller, switching 40 Amps per circuit at 100-277 Vac, and may be used in either freeze protection or process temperature control applications. The ITC's compact 10" x 8" x 6" NEMA 4X enclosure facilitates all of the electrical connections and it features a high resolution TFT display, PID or On/Off SSR control, selectable soft start program, dual RTD sensor input per circuit, current load and GFEP monitoring. All process variables may be monitored both locally and remotely. The ITC is designed for line or ambient sensing heat trace applications in hazardous (Class I, Division 2) or non-hazardous areas.

Should the ITC unit realize a failed sensor, the controller automatically switches into a user adjustable manual output duty cycle. This controller provides LED indication of load, power and alarm status for each circuit, has front panel capacitive touch user interface buttons and comes complete with heavy gage stainless steel mounting brackets.

#### IntelliTRACE Control, Monitoring and Distribution Panels

The IntelliTRACE ITAS and ITLS Series is a micro-processor based Control/Monitoring and Power Management and Distribution system for Heat Trace Applications. The ITAS and ITLS Series has models suitable for ordinary as well as Class I, Division 2 areas and will manage 6-72 circuits

The ITAS and ITLS Control Panel Series provides alarms for high / low temperatures, high/low current, ground fault leakage and sensor faults.

The 40 Amps per circuit capacity, the Integral Circuit Panel and the Soft Start feature save significant time, installation and maintenance costs.

The customizable I/O (Sensor) Mapping, the remote monitoring capability and the wireless communication option provide desirable process management flexibility options.