



FE-Series Constant-Wattage Heating Cable Instruction Manual

	<p>Read and understand this manual before installing this heater. Failure to understand how to safely install the heater could result in an accident causing serious injury or death. This heater should only be installed by qualified personnel.</p>
---	--

TABLE OF CONTENTS

Introduction	2
Safety Alert Symbol	2
Important Safety Instructions	3
Connection/Termination Kits Descriptions	4
Prior to Installation	4
Lead Termination Preparation	5
End Termination Preparation	6
Power Input Connection Installation	7
Splice Installation	8
Heating Cable Installation	9
Troubleshooting Guide.....	11
Warranty Information	12



SAFETY ALERT SYMBOL

The symbol above is used to call your attention to instructions concerning your personal safety. It points out important safety precautions. It means **“ATTENTION! Become Alert! Your Personal Safety is involved!”** Read the message that follows and be alert to the possibility of personal injury or death.



Immediate hazards which **WILL** result in severe personal injury or death.



Hazards or unsafe practices that **COULD** result in severe personal injury or death.



Hazards or unsafe practices that **COULD** result in minor personal injury or property damage.

INTRODUCTION

Thank you for purchasing a FE series constant-wattage heating cable system. A heating cable system is a combination of heating cable, connection / termination kits, temperature controller, and accessories based on your particular application. Your heater is designed to provide a long and efficient service life with function, reliability, and safety in mind.

All Constant-Wattage Heating Cable utilize a parallel resistance modular design. This allows the heating cable to be cut to length and terminated in the field, without affecting the heating power per unit length. The modular design enables the cable terminations / electrical connections to be made with cold leads and cold ends (e.g. cable not heated in electrical junction box).

A temperature controller is required for all constant-wattage heating cable.

SAVE THESE INSTRUCTIONS!

Additional copies of this manual are available upon request.

IMPORTANT SAFETY INSTRUCTIONS



⚠ DANGER
 A person who has not read and understood all operating Instructions is not qualified to operate this product.

⚠ DANGER

- Do not immerse heater in liquid.
- Heating sets must be 13mm (5/8") from any combustible material.
- Use heater only in approved locations.
- Keep sharp metal objects away from heater.

Failure to observe these warnings may result in electric shock, risk of fire, and personal injury.

⚠ WARNING

End-User Must Comply to the Following:

- Only qualified personnel are allowed to connect the electrical wiring.
- Disconnect all supply power at the source before making any heating cable power input connections.
- All electrical wiring must follow local electrical codes and highly recommend following NEC Article 427.
- The person who performs the final installation / wiring must be qualified for this work.
- The end-user is responsible for providing a suitable disconnecting device.
- The end-user is responsible for providing suitable electrical protection device. It is highly recommended that a ground fault circuit breaker be used.

Failure to observe these warnings may result in personal injury or damage to the heater.

Agency Approvals

CE

Ordinary Locations
 Hazardous Locations
 Class I, Division 2, Groups B, C, & D
 Class II, Division 2, Groups F & G
 Class III, Division 2

FM APPROVED

Ordinary Locations
 (120 and 230VAC only)

SP

Ordinary Locations
 (120 and 230VAC only)

Approvals valid only when installed in accordance with

⚠ CAUTION

- Never handle the heater while it is in operation; always disconnect the heater from the power source and allow to cool prior to handling.
- Inspect heater and connection kits before use.
- Never operate heater without a temperature control device.
- Do not wrap the heating cable over itself.
- If spillage of foreign matter onto heater occurs, disconnect from power source and clean after heater is allowed to cool.
- Never operate a heater without an appropriate heat sink (device being heated is considered a heat sink).
- Do not operate heater above rated temperature value.
- Fasten heater to device using approved methods only.
- Do not repair damaged or faulty heaters.
- Do not crush or apply severe physical stress on heater or cord assembly.
- Disconnect heater when not in use.

Failure to observe these warnings may result in personal injury or damage to the heater.

CONNECTION / TERMINATION KIT DESCRIPTIONS

FECABUC:
Universal Connection/Termination Kit

- 1-1" NPT Pipe standoff
- 2-Ring terminals
- 3-Wire nuts
- 2-Crimp barrels
- 3-Lead pouches
- 2-End pouches
- 1-Caution label
- 6-Shrink tubes
- 1-Panhead screw
- 1-3 oz. tube RTV sealant
- 2-Pipe straps

Enough to complete: Two end terminations and one power input connection, or one power input splice.

Additional Required Hardware: Double hub junction box.

FECABKC:
Lead/ End Termination Kit

- 5-Lead pouches
- 5-End pouches
- 1-3 oz. tube RTV sealant

Enough to complete: Five lead and end terminations.

PRIOR TO INSTALLATION

STEP 1:

Check for suspected damage to heater like rips, punctures, etc. Ensure surface to be heated is free of jagged or sharp edges or weld splatter.

STEP 2:

Confirm all necessary installation hardware and tools are readily available. Depending on the application and kit, this may include.

Tools

- | | | |
|----------------------|-------------------------------|-------------|
| Diagonal Cutter | Crimping Tool / Wire Stripper | Heat Gun |
| Measuring Tape/Ruler | Knife | Screwdriver |

Hardware and Accessories

- | | | |
|---|---|--|
| <ul style="list-style-type: none"> Temperature Controller Temperature Sensor Connection / Termination Kits
<i>(see kit descriptions to verify contents and additional required hardware)</i> | <ul style="list-style-type: none"> Insulating Material Monitor Light Kit (Optional) RTV Sealant Pipe Straps Junction Box 1" NPT Wire Nuts | <ul style="list-style-type: none"> Caution Labels Aluminum or Fiberglass Adhesive Tape (verify temperature rating) Heat Conductive Putty Pipe Standoffs 1" NPT |
|---|---|--|

STEP 3:

(A) Verify the total amperage of the system does not exceed the maximum amperage that the heating system components can handle. (B) Verify that the total length of cable required does not exceed the maximum circuit length. If the cable length exceeds (A) or (B), the cable must be divided into sections.

LEAD TERMINATION PREPARATION

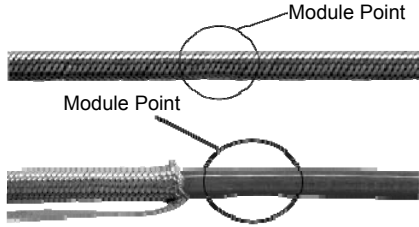

STEP 1:
Determine the module length of the heating cable. Module points can be identified by slight indentations on the rounded surface of the outer jacket. You can determine the module point by touch or visually by sliding back the metallic overbraid.



STEP 2:
Cut the cable between the module points for the desired length of cold lead. The length of "cold lead" must be at least 12" (30.5cm) but no longer than the module length minus 6" (15.2cm). The section of cable between the end of the cable and the first module point will be the cold lead. This section will be used for lead termination / power input connection.



STEP 3A:
Push 6" (15.2cm) of the metallic overbraid back to expose the extruded jacket on the cable. Using a pair of Wire Cutters, cut off 4" (10.1cm) of the exposed cable.



STEP 4:
Pull the metallic braid back over the end of the cable. Push the cable through the side of the metallic braid. Twist the empty braid to form a pigtail lead and crimp a ring terminal on the end (see picture above). A crimp barrel can also be used to extend the ground (braid) to another 12AWG Ground wire.

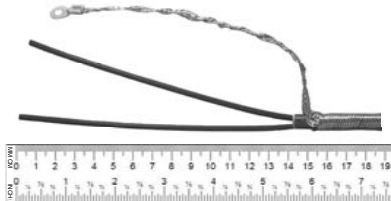

STEP 5:
Slide the metallic overbraid back at least an additional 6" (15.2cm) to further expose the cable jacket. Using a knife, carefully cut and remove 6" (15.2cm) of the extruded jacket to expose the spirally wrapped resistance wire and the two bus wires. Do **NOT** damage the bus wires or the bus wire insulation; the resistance wire must **NOT** come into contact with the exposed bus wires. Unwrap and cut the resistance wire back to the point you cut the cable jacket.



STEP 6:
Slide a lead pouch over the two bus wires and over the extruded jacket. Push the metallic braid up to the lead pouch. Slide a shrink tube over the lead pouch and the metallic braid. Using a heat gun or other appropriate heating device, apply heat evenly over the entire surface of the tube, shrinking it over the metallic braid and lead pouch. Using wire strippers, remove 0.75" (1.9cm) of the insulation from the bus wires to expose the conductors.

END TERMINATION PREPARATION

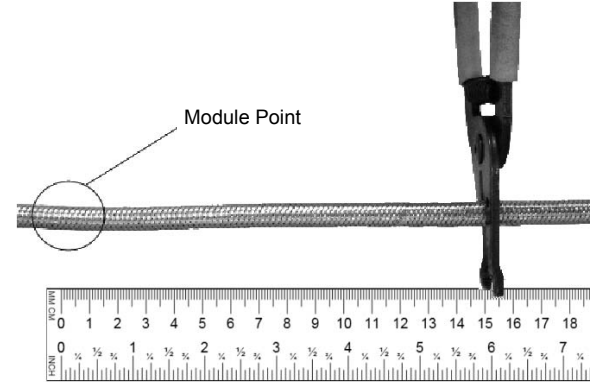

STEP 1:
Locate the last module point of the cable run. Cut the cable 6" (15.2cm) beyond this point to form a cold end.



STEP 2:
Using diagonal cutters and / or a knife, remove 0.75" (1.9cm) of the metallic braid and 0.50" (1.2cm) of the extruded jacket to expose the inner wrap. Remove the inner wrap back to the extruded jacket to expose the spirally wrapped resistance wire and the two insulated bus wires. Unwrap and cut off the resistance wire back to the inner wrap. Be careful not to damage the insulation on the bus wires. Cut one of the bus wires 0.25" (0.6cm) shorter than the other one. Make certain the resistance wire, the two bus wires, and the metallic braid do **NOT** contact each other.



STEP 3:
Slide an end pouch over the two bus wires and extruded jacket. Slide a shrink tube over the end pouch and the metallic overbraid. Using a heat gun or other appropriate heating device, apply heat evenly over the entire surface of the tube, shrinking it over the metallic braid and end pouch.

NOTE: When attaching the heating cable to the pipe, make sure that the last module point is in contact with the pipe surface.

POWER INPUT CONNECTION INSTALLATION

⚠ WARNING

Only authorized and trained personnel should perform the following procedure. The hazard of electrical shock exists with any electrical installation project. Disconnect all supply power at the source prior to making the heating cable power input connections.

⚠ CAUTION

A temperature controller is required for all constant-wattage heating cable.

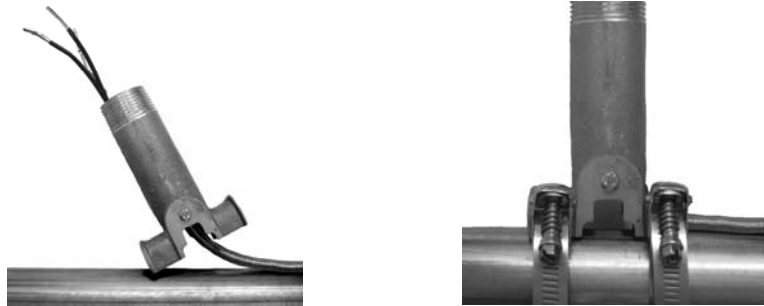

STEP 1:

Prepare heating cable end as specified under "Lead Termination Preparation". Insert approximately 8" (20cm) of the heating cable(s) through the bottom of the cast aluminum pipe standoff, making sure the first module point stays in contact with the pipe.

NOTE: A maximum of three cables fit through pipe standoff.

STEP 2:

Place the standoff on the pipe surface at the point where the supply wiring and associated fittings will connect to the pipe heat tracing cable. Fasten the standoff to the pipe with pipe straps. Fill the top of the standoff with Silicone RTV to provide a moisture seal between the pipe and electrical junction box. Make certain there are no voids between the cable and pipe standoff. Allow an appropriate amount of time for the Silicone RTV to cure.

STEP 3:

Secure an appropriately sized junction box on the standoff. The standoff is supplied with a 1" NPT fitting. Pull the wiring through the associated fittings into the junction box and connect the heating cable(s) bus wires to the temperature controller with wire nuts. If applicable, secure the braided pigtail to the standoff with the ground screw or to the junction box with the panhead screw. Test the cable installation for continuity and insulation resistance. The insulation resistance between the bus wires and the metallic braid must be greater than 50 megohms at 500 volts. Close the junction box and attach the Caution Label to the cover of the junction box.



SPLICE INSTALLATION

⚠ WARNING

Only authorized and trained personnel should perform the following procedure. The hazard of electrical shock exists with any electrical installation project. Disconnect all supply power at the source prior to making the heating cable power input connections.

STEP 1:

Prepare the heating cable ends to be spliced together as specified under "Lead Termination Preparation".

CAUTION: Never connect the two parallel conductors of the heating cable together.

STEP 2:

Insert the heating cable cold leads up through the pipe standoff and into the junction box. Attach the pipe standoff and junction box to the pipe where the splice is to be located. Fasten it with appropriately sized pipe clamps.

NOTE: A maximum of three cables fit through pipe standoff.

STEP 3:

Connect the leads of the heating cable ends together using wire nuts as shown in the illustrations (wire nuts are not provided with FECABSK).

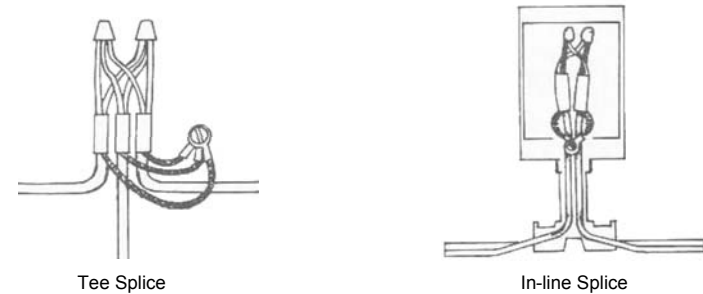

STEP 4:

Connect the terminal lugs on the braid leads to a grounded screw on the pipe standoff or on the junction box.

NOTE: The junction box and pipe standoff must be grounded.

STEP 5:

Test the cable installation for continuity and insulation resistance. The insulation resistance between the bus wires and the metallic braid must be greater than 50 megohms at 500 volts. Close the junction box and attach the Caution Label to the cover of the junction box.

HEATING CABLE INSTALLATION

CAUTION

Minimum installation temperature: -22°F (-30°C)

Cable Wrapping Techniques

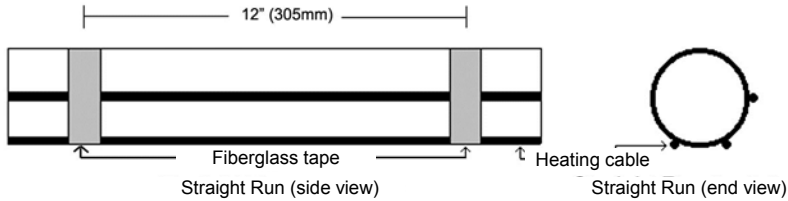

A straight run is the simplest method to installing heating cable. It is possible to have multiple straight runs on a single object. With a single straight run, position cable at the bottom of a horizontal pipe.

CAUTION Do not wrap the heating cable over itself or have two heating cables touch.

All parts of heating cable must make intimate contact with surface to be heated. Use heat conductive putty to fill voids between cable and pipe surface.

Wrap adhesive tape every 12" (305mm) around heating cable and pipe to attach the cable. Minimum insulation resistance acceptable after the system has been installed and thermally insulated: The measurement made by applying 500Vdc between each circuit and ground with the set de-energized and all circuit neutrals isolated from ground.

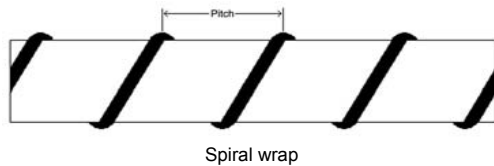

Spiral wrapping provides more heater coverage than a straight run. It can also require more heating cable. Verify the pitch length (see illustration) prior to installation to ensure you have enough heating cable to finish the job.

CAUTION Do not wrap the heating cable over itself or have two heating cables touch.

All parts of heating cable must make intimate contact with surface to be heated. Use heat conductive putty to fill voids between cable and pipe surface.

Wrap adhesive tape every 12" (305mm) around heating cable and pipe to attach the cable.

Minimum insulation resistance acceptable after the system has been installed and thermally insulated: The measurement made by applying 500Vdc between each circuit and ground with the set de-energized and all circuit neutrals isolated from ground.

Heating Cable Placement on Different Types of Objects

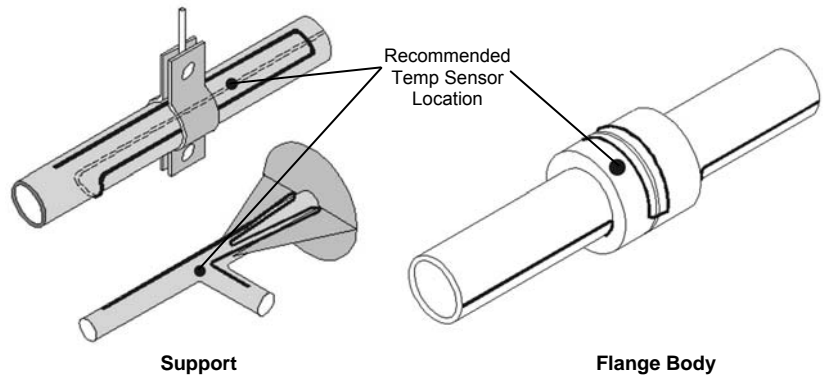
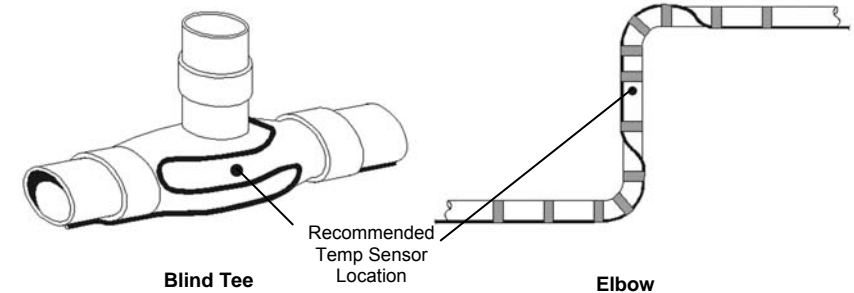
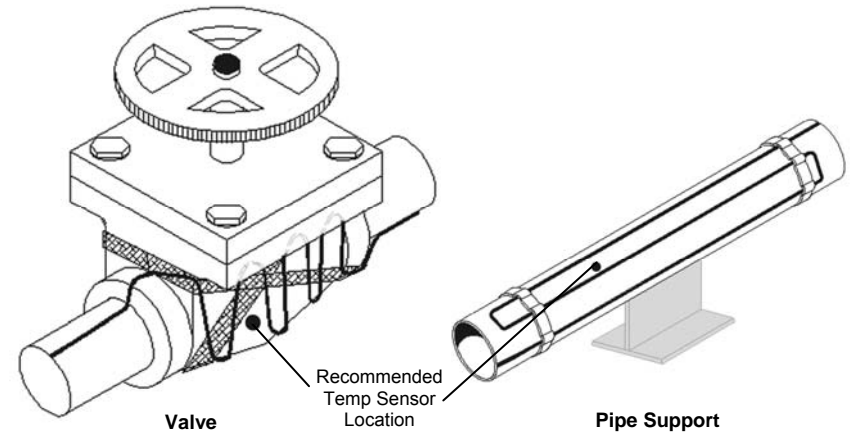

TROUBLESHOOTING GUIDE

PROBLEM	SOLUTION(S)
Entire heating cable run does not heat	Verify heater is connected to proper voltage. Check to see if there is a resistance reading (not an open circuit) in heater using an ohm meter.
Portion of heating cable does not heat	Examine unheated module for damage.
Circuit breaker is tripping	Validate that the circuit breaker is capable of handling the amp requirement of heater. Examine heater and power wiring for any damage. Verify open circuit exists between bus wire and ground braid.

Maximum Circuit Length in ft (m)

Cable	120VAC	208VAC	230VAC	277VAC	480VAC
3 watts/ ft. (10 watts/m)	360 (110)	625 (191)	720 (220)	N/A	1440 (439)
5 watts/ft. (16 watts/m)	275 (84)	477 (145)	550 (168)	N/A	1100 (335)
8 watts/ ft. (26 watts/m)	220 (67)	381 (116)	440 (134)	508 (155)	880 (268)
12 watts/ ft. (39 watts/m)	180 (55)	312 (95)	360 (110)	416 (127)	720 (220)



3522 Central Pike, Building 203, Hermitage TN 37076
Phone: (615) 834-4044 Fax: (615) 834-5834

Order our products at www.heatingelementsplus.com