

QUICK-REFERENCE INSTALLATION GUIDE



TRACON® MODEL GPT-230

DUAL-POINT GENERAL PURPOSE HEAT-TRACE CONTROL

PACKING LIST

QTY.	PART NO.	DESCRIPTION
1	25171	TRACON MODEL GPT 230 Dual-Point General Purpose Heat-Trace Control
2	25076	Temperature Sensor
1	25300	GPT230 Quick-Reference Installation Guide (this document)
-	25167	TRACON MODEL GPT-230 Installation & Operation Manual

PRIOR TO INSTALLATION

1. Read these installation instructions and manual prior to beginning installation.
2. Install this device only if you are a qualified electrician trained to perform such work.
3. Before beginning installation, lay out the system components, the heat trace cable and the temperature probe in their approximate locations to visualize the system and evaluate exact component and junction box placement, as well as required cable and conduit lengths.

INSTALLATION

The GPT 230 Automatic Heat-Trace Control should be installed by a qualified, licensed electrician. Installation must conform to all applicable local and national electrical codes and laws. The unit's NEMA 4X IP 66 enclosure allows for indoor or outdoor applications.

The GPT 230 controller has an ambient operating temperature range of -40 °F to 131 °F (-40 °C to 55 °C). To avoid potential internal condensation mount the unit out of direct sunlight.

Install the GPT on a fixed, flat, vertical surface using the unit's mounting flanges. The mounting flanges accommodate 1/4" or 6.3 mm fasteners.

The GPT 230's nonmetallic enclosure has one 1.046" hole for conduit entry; this can hold both power and load wiring.

Use only Listed Type 4X IP66 liquid-tight conduit hubs or cable glands. Connect the hub to the conduit system before connecting the hub to the enclosure.

The unit comes with two installed liquid-tight cable glands. One of these fittings is for the temperature sensor cable, and the other is for the alarm relay cable.

The cable glands can accommodate cable diameters 0.08" to 0.24" (2 mm to 6 mm). The temperature sensor may be located up to 2,000' (610m) from the GPT.

There is a removable electrical insulation divider that must be in place when there is power applied to the unit. All leads should be terminated; no unsecured leads should be left inside the wiring compartment.

QUICK-REFERENCE INSTALLATION GUIDE

FIGURE 1. The GPT 230 wiring layout.

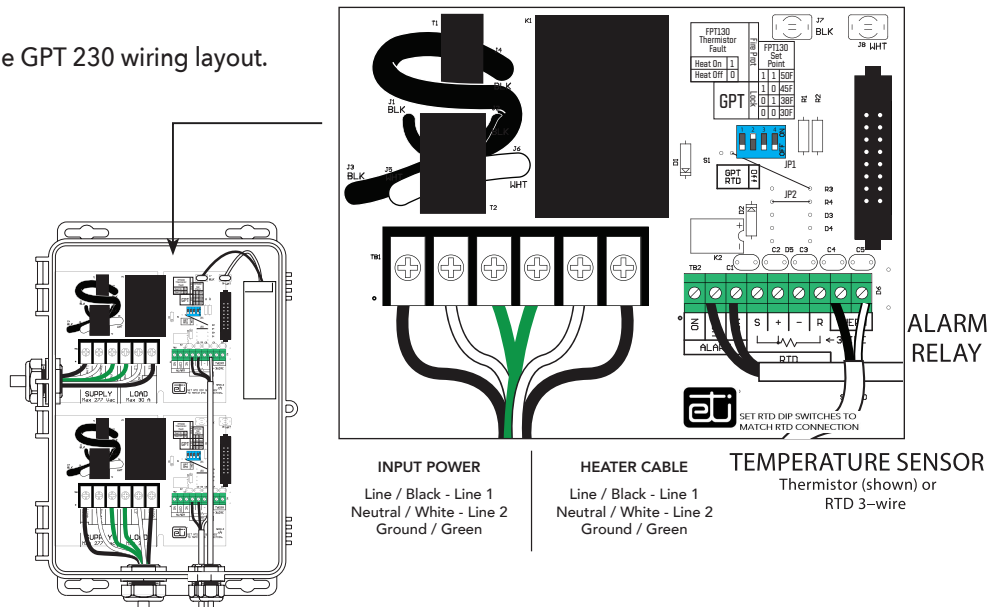
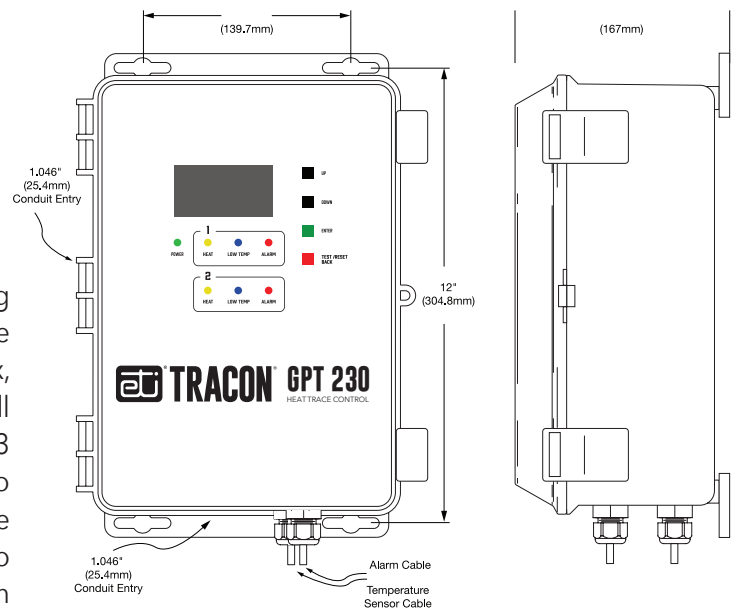

FIGURE 2. Mounting dimensions.

1. INSTALL THE CONTROL BOX

Use the box itself as a template to determine the mounting hole footprint. Install the box to a solid, stable surface capable of supporting four times the weight of the box, or about 20 pounds. Use all four mounting holes. Install the control box to the wall using heavy-duty 1/4" or 6.3 mm fasteners long enough to fasten the box securely. Do not fully tighten mounting hardware at this time. Leave the mounting hardware loose enough to work the conduit into place. Hardware will be fully tightened following installation of the conduit.



NOTE:

Perform the following steps with the circuit breaker to the unit OFF. The TRACON GPT 230- is permanently connected equipment and does not have an internal disconnect device. When power is applied, the system will start.

QUICK-REFERENCE INSTALLATION GUIDE

2. CONNECT THE SUPPLY AND LOAD

Feed the Input Supply (Input Power) and the Load (Heater Cable) through the Conduit Entry Hole in the enclosure as shown, then connect the leads, as shown in the Figure 3. Line is black; neutral is white; ground is green.

Note: Both the power and the load require a #10 AWG wire.

3. INSTALL THE TEMPERATURE SENSOR

The GPT 230 can use either a thermistor (provided), or a 3-wire RTD sensor.

Thermistor (25076)

The GPT 230 comes with a thermistor temperature sensor with a 20 ft. jacketed cable that has an operating range of -40°F to 230°F (-40°C to 110°C). See the diagram below for proper wiring and DIP switch configuration when using a thermistor sensor. Refer to Figure 4.

RTD

The unit can use an RTD sensor for applications requiring a wider temperature range. The GPT 230 can operate with 3-wire RTD sensors. Refer to Figure 4.

Note: The sensor must be selected in the Sensor Type parameter setting screen also.

4. INSTALL THE EXTERNAL ALARM

An alarm or power-off condition can be communicated by either opening or closing a relay contact. It is important to make the proper alarm relay connections to achieve the desired result. The middle terminal labeled COM (Common) is used in both wiring configurations. Connect one alarm relay lead to the COM terminal. If the system needs a contact to close to signal an alarm or power-off condition, connect the other alarm relay lead to the NC (Normally Closed) terminal.

If the system needs a contact to open to signal an alarm or power-off condition, then connect the other alarm relay lead to the NO (Normally Open) terminal.

If the unit has power, and there are no alarm conditions then the NO and COM terminals will be connected.

the unit loses power or an alarm condition occurs then the NC and COM terminals will be connected. Refer to Figure 5.

5. PANEL LOCKOUT

To prevent unauthorized changes of control settings, the second DIP switch can be set to the on position to Lock the settings. With Lock enabled, the control panel will allow viewing but not changing any of the settings; only the $^{\circ}\text{C}$ or $^{\circ}\text{F}$ option can be selected. Refer to Figure 6.

Note: The GPT reads the Lock DIP switch position when the Settings screen is entered. If the switch is changed, you need to re-enter the Settings screen.

FIGURE 3. Contractor connections.

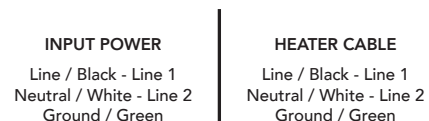
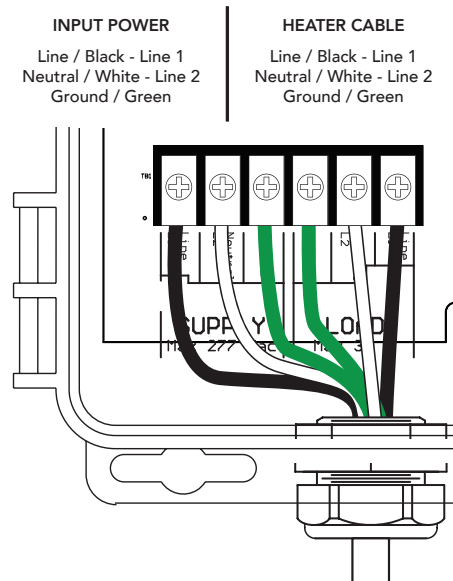
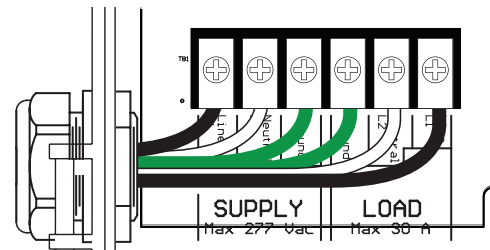

QUICK-REFERENCE INSTALLATION GUIDE

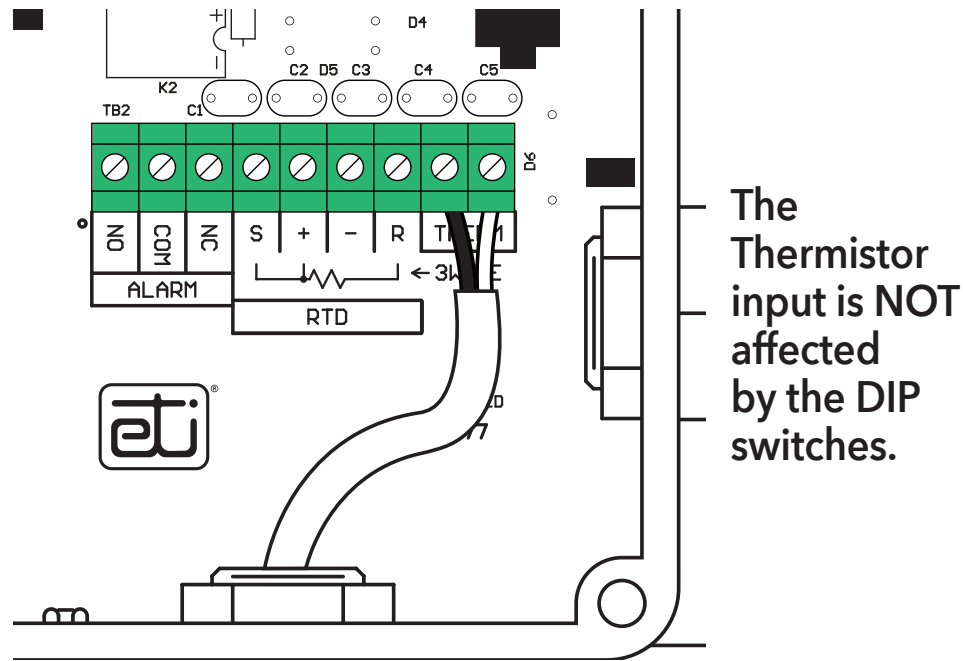

FIGURE 4. Temperature sensor wiring

6. INSTALL THE CONDUIT AND FULLY

TIGHTEN HARDWARE

Install the conduit runs to the control box. Use only Listed Type 4X IP66 liquid-tight conduit hubs. With cabling routed through conduit and conduit is secure, fully tighten the control box mounting hardware and re-assemble control box panels and cover in their original location.

Note: At this point the circuit breaker to the unit can be turned on providing power to the unit.

7. SETUP AND SETTINGS EDITING

Please refer to the GPT 230 Manual for comprehensive instructions for Setup and Settings Editing.

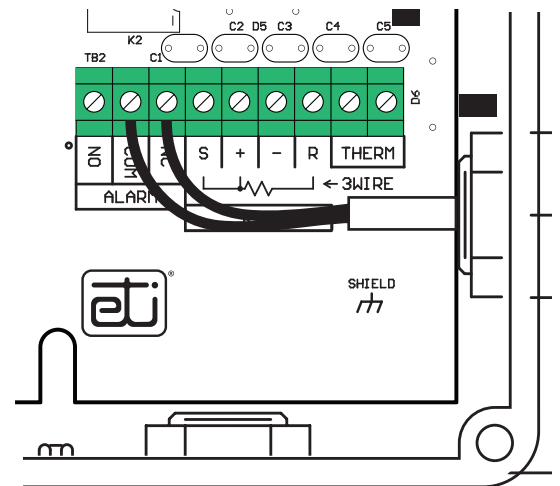

FIGURE 5. External alarm connection



FIGURE 6. Panel lockout DIP switch configuration

QUICK-REFERENCE INSTALLATION GUIDE



Pilot Duty

The GPT 230 Automatic Heat-Trace Control with GFEP cannot be used for Pilot Duty applications.

Devoir du pilote

Le thermostat à usage général GPT 230 avec GFEP ne peut pas être utilisé pour les applications Pilot Duty



Resistive Load Usage Only

This product is not for use with Inductive loads. Inductive loads may create nuisance tripping of the Ground-Fault Equipment Protection circuit.

Utilisation de charge résistive uniquement

Ce produit n'est pas destiné à être utilisé avec des charges inductives. Les charges inductives peuvent créer un déclenchement intempestif du circuit de protection de l'équipement contre les défauts à la terre



Abnormal Odor or Smoke

In the event of smoke or a burning or abnormal odor, immediately interrupt power to the unit by turning off the circuit breaker protecting the unit.

Odeur ou fumée anormale

En cas de fumée ou de brûlure ou d'odeur anormale, coupez immédiatement l'alimentation de l'unité en fermant le disjoncteur protégeant l'unité.



Electrical Shock / Fire Hazard

Any installation involving electric heater wiring must be grounded to earth to protect against shock and fire hazard. Suitable ground fault detection and interrupting systems must be in use at all times to reduce shock and fire hazard and to protect equipment.



Electric wiring to heating elements must be installed in accordance with National Electrical Code (NEC)/ Canadian Electrical Code requirements, as well as all other local and applicable electrical codes and any thirdparty standards. This product is intended for commercial and industrial applications. Follow the installation instructions contained in this manual and those provided by the heater manufacturer.

Size the circuit breaker appropriately for the expected load and inrush current. The maximum rated current for the GPT 230 is 30 amps with resistive load.

Heater loads and their controls should not share a circuit branch with other types of equipment. A shared circuit may result in electromagnetic interference that can affect system operation.

Make certain that the heater shield is properly grounded . Failure to do so may result in damage to the equipment or fire.

Following installation and prior to beginning system operation, refer to and perform the Post-Installation Test described in this manual.

Risque de choc électrique / d'incendie

Toute installation impliquant un câblage de chauffage électrique doit être mise à la terre pour se protéger contre les chocs et les risques d'incendie . Des systèmes appropriés de détection et d'interruption des défauts à la terre doivent toujours être utilisés pour réduire les risques de choc et d'incendie et protéger l'équipement. Le câblage électrique des éléments chauffants doit être installé conformément aux exigences du Code national de l'électricité (NEC) / du Code canadien de l'électricité ainsi qu'à tous les autres codes électriques locaux et applicables et à toute norme tierce . Ce produit est destiné aux applications commerciales et industrielles . Suivez les instructions d'installation contenues dans

QUICK-REFERENCE INSTALLATION GUIDE



ce manuel et celles fournies par le fabricant de l'appareil de chauffage .



Dimensionnez le disjoncteur en fonction de la charge et du courant d'appel attendus. Le courant nominal maximum pour le GPT 230 est de 30 ampères avec une charge résistive.



Les charges de chauffage et leurs commandes ne doivent pas partager une branche de circuit avec d'autres types d'équipement. Un circuit partagé peut entraîner des interférences



électromagnétiques qui peuvent affecter opération Système. Assurez-vous que le blindage du radiateur est correctement



mis à la terre . Ne pas le faire peut endommager l'équipement ou



provoquer un incendie.

Après l'installation et avant de commencer le fonctionnement du système, reportez-vous et effectuez le test de post-installation décrit dans ce manuel.

LIMITED WARRANTY

ETI's two year limited warranty covering defects in workmanship and materials applies. Contact Customer Service for complete warranty information.

DISCLAIMER

ETI makes no representations or warranties, either expressed or implied, with respect to the contents of this publication or the products that it describes, and specifically disclaims any implied warranties of merchantability or fitness for any particular purpose. ETI reserves the right to revise this publication, and to make changes and improvements to the products described in this publication, without the obligation of ETI to notify any person or organization of such revisions, changes or improvements.